

# CILINDRI PNEUMATICI COMPATTI

*Compact pneumatic cylinders*

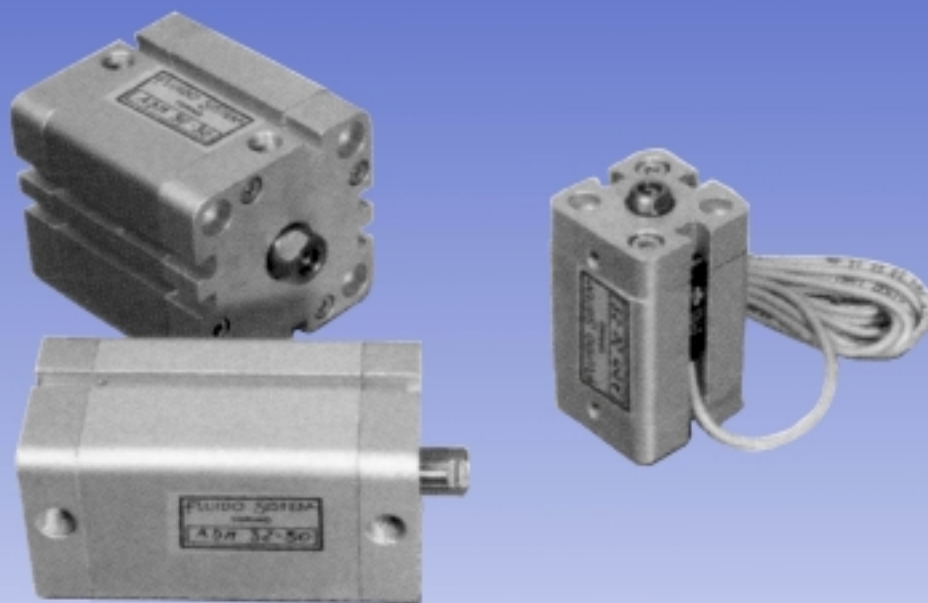

Serie **CBU**

**FLUIDO SISTEM S.r.l.**

Via Nicomede Bianchi, 61/3 - 10146 TORINO (Italy)  
Tel. +39 011.797.322 - 011.797.420 / Fax +39 011.797.412  
E-mail: [fluidosistem@mclink.it](mailto:fluidosistem@mclink.it) - Web: [www.fluidosistem.it](http://www.fluidosistem.it)

# CILINDRI CORSA BREVE COMPATTI SHORT STROKE COMPACT CYLINDERS

## CARATTERISTICHE COSTRUTTIVE / FEATURES ON STRUCTURE

CILINDRI CORSA BREVE COMPATTI serie "CBU"	SHORT STROKE COMPACT CYLINDERS "CBU" series
<p>La nuova serie di cilindri compatti "CBU", disponibile nei diametri da 16 a 100 mm., rappresenta la più avanzata evoluzione dei cilindri a corsa breve tradizionali.</p> <p>Le principali caratteristiche tecniche sono:</p> <ul style="list-style-type: none"> <li>• Standard costruttivo: Europeo (Unitop); nei diametri da 32 a 100 mm., i cilindri possono essere forniti con le misure degli interassi e dei fori di fissaggio secondo le norme ISO 6431-VDMA.</li> <li>• Tutti i cilindri sono predisposti per l'azionamento dei finecorsa magnetici, che non sporgono dalla sagoma del cilindro, consentendo sensibili risparmi di spazio.</li> <li>• Le guarnizioni dello stelo e del pistone sono in poliuretano e garantiscono una lunga durata anche nel funzionamento con aria non lubrificata.</li> <li>• Guida dello stelo: la testata anteriore del cilindro, essendo fissata rigidamente alla camicia, consente un'ottima guida dello stelo e la possibilità di costruire cilindri con corse massime fino a 400 mm. (in funzione dell'alesaggio del cilindro).</li> <li>• Tutti i cilindri sono forniti di ammortizzamento di fine-corsa elastico sul pistone.</li> <li>• Temperatura di funzionamento: -30°C ÷ +80°C</li> </ul>	<p>The new "CBU" series of compact cylinders, available in the diameters from 16 to 100 mm, represents the most advanced evolution of traditional short stroke cylinders.</p> <p>The main technical features are the following:</p> <ul style="list-style-type: none"> <li>• Construction standard: European (Unitop); in the diameters from 32 to 100, the cylinders can be supplied with interaxial and fixing bores measures according to ISO 6431-VDMA rules.</li> <li>• All cylinders are prepared for the employment of magnetic end stroke switches, which do not extend themselves from the structure of the cylinder, allowing sensible space savings.</li> <li>• The rod and piston gaskets are in polyurethane and they guarantee a long duration also in the employment with no lubricated air.</li> <li>• Rod guide: the front head of the cylinder, being firmly fixed to the tube, allows an excellent rod guiding and the possibility to manufacture cylinders with maximum strokes up to 400 mm. (according to the cylinder bore)</li> <li>• All cylinders are supplied with elastic damping device of end stroke on the piston.</li> <li>• Working temperature: -30°C ÷ +80°C</li> </ul>

TIPO DI CILINDRO CYLINDER TYPE	CILINDRI CBU CYLINDERS			CILINDRI CBUA CYLINDERS			CILINDRI CBUP CYLINDERS			CILINDRI CBUMA CYLINDERS			CILINDRI CBUMP CYLINDERS		
	Forza in spinta Push force P=6bar N	Forza in tiro Pull force P=6bar N	Press. di esercizio Pressure range bar	Forza in spinta Push force P=6bar N	Forza in tiro Pull force P=6bar N	Press. di esercizio Pressure range bar	Forza in spinta Push force P=6bar N	Forza in tiro Pull force P=6bar N	Press. di esercizio Pressure range bar	Forza in spinta Push force P=6bar N	Forza in tiro Pull force P=6bar N	Press. di esercizio Pressure range bar	Forza in spinta Push force P=6bar N	Forza in tiro Pull force P=6bar N	Press. di esercizio Pressure range bar
<b>CBU...12-16</b>	121	91	1,1-10	121	91	1,6-10	91	91	1,4-10	110	6	1,6-10	6	81	2,1-10
<b>CBU... 20</b>	188	142	1-10	188	142	1,5-10	142	142	1,3-10	174	7	1,4-10	7	128	1,9-10
<b>CBU... 25</b>	295	248	0,8-10	295	248	1,2-10	248	248	1-10	270	12	1,3-10	12	224	1,6-10
<b>CBU... 32</b>	482	415	0,7-10	482	415	1,1-10	415	415	0,9-10	450	16	1,1-10	16	384	1,3-10
<b>CBU... 40</b>	754	687	0,6-10	754	687	0,9-10	687	687	0,8-10	708	23	1-10	23	642	1,1-10
<b>CBU... 50</b>	1178	1058	0,5-10	1178	1058	0,8-10	1058	1058	0,7-10	1120	30	0,9-10	30	1002	1-10
<b>CBU... 63</b>	1869	1750	0,4-10	1869	1750	0,7-10	1750	1750	0,6-10	1800	35	0,8-10	35	1682	0,9-10
<b>CBU... 80</b>	3014	2829	0,4-10	3014	2829	0,6-10	2829	2829	0,5-10	2900	60	0,7-10	60	2715	0,8-10
<b>CBU... 100</b>	4710	4420	0,3-10	4710	4420	0,5-10	4420	4420	0,4-10	4520	100	0,6-10	100	4231	0,7-10

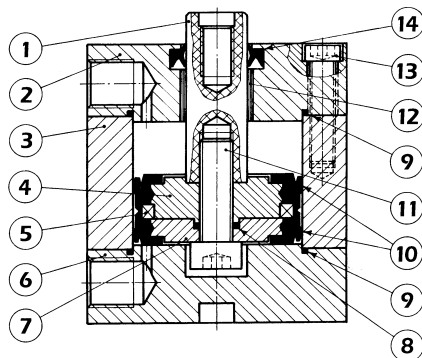

### Pos. Denominazione / Description

- 1 Stelo / Piston rod
- 2 Testata anteriore / Front head
- 3 Corpo cilindro / Cylinder body
- 4 Semi pistone / Half piston
- 5 Magnete / Magnet
- 6 Testata posteriore / Rear head
- 7 Semi pistone / Half piston
- 8 OR
- 9 OR
- 10 Guarnizione pistone / Piston seal
- 11 Vite pistone / Piston screw
- 12 Boccola stelo / Rod Bushing
- 13 Vite testata / Head screw
- 14 Guarnizione stelo / Rod seal

### Materiale / Material

- Acciaio inossidabile / Stainless steel
- Alluminio anodizzato / Anodized aluminium
- Alluminio ossidato duro / Hard anodized aluminium
- Alluminio / Aluminium
- Plastoferrite / Rubber magnet
- Alluminio anodizzato / Anodized aluminium
- Alluminio / Aluminium
- NBR
- NBR
- Poliuretano / Polyurethanes PU 90° Sh A
- Acciaio / Carbon steel
- Bronzo + PTFE / Bronze + PTFE
- Acciaio zincato / Galvanized carbon steel
- Poliuretano / Polyurethanes PU 90° Sh A

# CILINDRI CORSA BREVE COMPATTI SHORT STROKE COMPACT CYLINDERS

## DIMENSIONI D'INGOMBRO / OVERALL SIZE

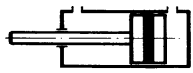

**CBU**

### CILINDRI A DOPPIO EFFETTO MAGNETICI DOUBLE ACTING MAGNETIC CYLINDERS

Ø 12 – 16 – 20 – 25

Ø 32 – 40 – 50 – 63 – 80 – 100

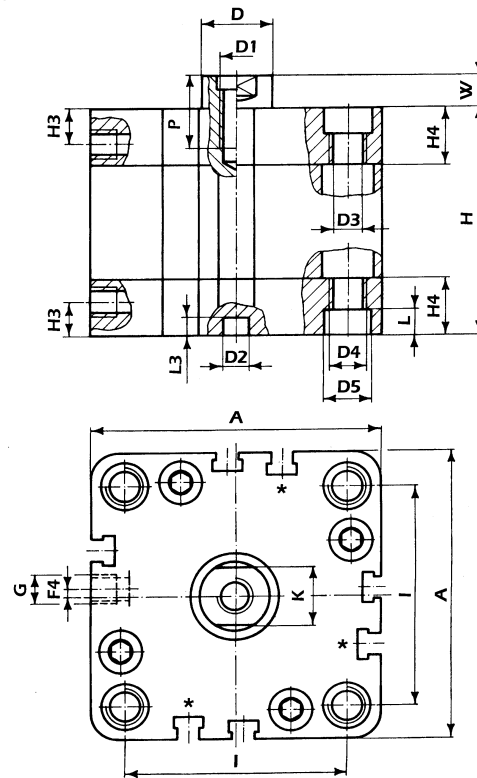
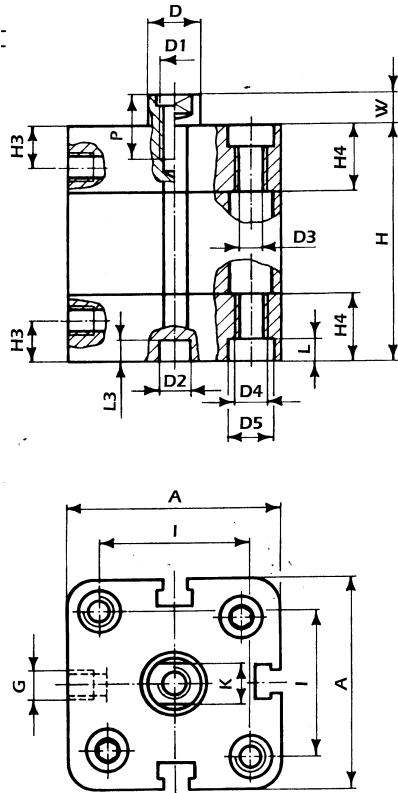

I cilindri Ø 32 e 40 mm, hanno solo 3 cave

The cylinders Ø 32 and 40 mm have only 3 slots

TIPO TYPE	A	D Ø	D1 Ø	D2 Ø	D3 Ø	D4 Ø	D5 Ø	F4	G	H3	H4	I	K	L	L3	P	W
CBU 12	29	6	M3	6	3.3	M4	6	0	M5	8	12.25	18	5	3.5	4	6	4.5
CBU 16	29	8	M4	6	3.3	M4	6	0	M5	8	12.25	18	6	3.5	4	8	4.5
CBU 20	36	10	M5	6	4.2	M5	7.5	0	M5	8	12.25	22	8	4.5	4	10	4.5
CBU 25	40	10	M5	6	4.2	M5	7.5	0	M5	8	12.75	26	8	4.5	4	10	5.5
CBU 32	50	12	M6	6	5.2	M6	9	4	1/8"	8	14.5	32	10	5.5	4	12	6
CBU 40	58	12	M6	6	5.2	M6	9	3	1/8"	8	14.75	42	10	5.5	4	12	6.5
CBU 50	67	16	M8	6	6.7	M8	10.5	0	1/8"	8	14.75	50	13	6.5	4	12	7.5
CBU 63	80	16	M8	8	8.5	M10	13.5	0	1/8"	8	14.25	62	13	8.5	4	14	7.5
CBU 80	100	20	M10	8	8.5	M10	13.5	0	1/8"	8.5	16	82	17	8.5	4	15	8
CBU 100	124	25	M12	8	8.5	M10	13.5	0	1/4"	10.5	19.25	103	22	8.5	4	20	10

Tipo / Type	Corsa / Stroke		H															
	5	10	15	20	25	30	40	50	60	70	80	90	100	125	160	200	250	
CBU 12	43	48	53	58	63	68	78	88	98	108	118	128	138	-	-	-	-	
CBU 16	43	48	53	58	63	68	78	88	98	108	118	128	138	163	-	-	-	
CBU 20	43	48	53	58	63	68	78	88	98	108	118	128	138	163	198	-	-	
CBU 25	44.5	49.5	54.5	59.5	64.5	69.5	79.5	89.5	99.5	109.5	119.5	129.5	139.5	164.5	199.5	-	-	
CBU 32	49.5	54.5	59.5	64.5	69.5	74.5	84.5	94.5	104.5	114.5	124.5	134.5	144.5	169.5	204.5	244.5	-	
CBU 40	50.5	55.5	60.5	65.5	70.5	75.5	85.5	95.5	105.5	115.5	125.5	135.5	145.5	170.5	205.5	245.5	-	
CBU 50	50.5	55.5	60.5	65.5	70.5	75.5	85.5	95.5	105.5	115.5	125.5	135.5	145.5	170.5	205.5	245.5	295.5	
CBU 63	-	60	65	70	75	80	90	100	110	120	130	140	150	175	210	250	300	
CBU 80	-	66	71	76	81	86	96	106	116	126	136	146	156	181	216	256	306	
CBU 100	-	76.5	81.5	86.5	91.5	96.5	106.5	116.5	126.5	136.5	146.5	156.5	166.5	191.5	226.5	266.5	316.5	

# CILINDRI CORSA BREVE COMPATTI SHORT STROKE COMPACT CYLINDERS

## DIMENSIONI D'INGOMBRO / OVERALL SIZE

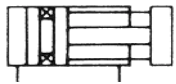

**CBUA**

**CILINDRI A DOPPIO EFFETTO MAGNETICI ANTIROTATIVI**  
*DOUBLE ACTING MAGNETIC ANTIROTARY CYLINDERS*

Ø 16 – 20 – 25

Ø 32 – 40 – 50 – 63 – 80 – 100

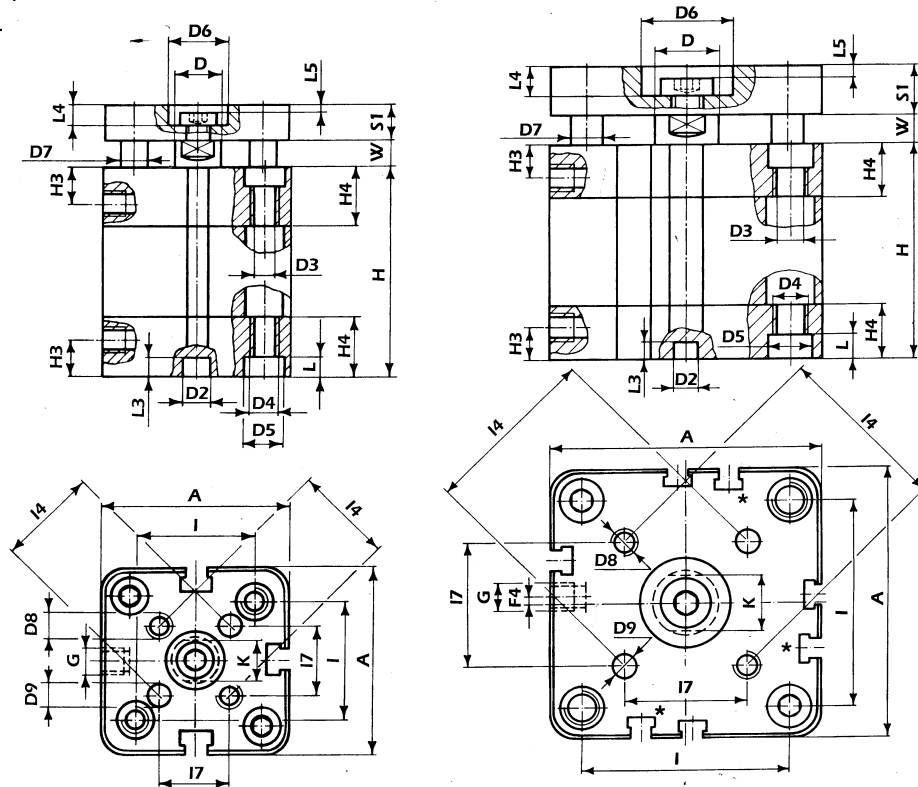

I cilindri Ø 32 e 40 mm, hanno solo 3 cave

The cylinders Ø 32 and 40 mm have only 3 slots

TIPO TYPE	A	D Ø	D2 Ø	D3 Ø	D4 Ø	D5 Ø	D6 Ø	D7 Ø	D8 Ø	D9 Ø	F4	G	H3	H4	I	I4	I7	K	L	L3	L4	L5	S1	W
CBUA 16	29	8	6	3.3	M4	6	9	5	M3	3	0	M5	8	12.25	18	14	9.9	6	3.5	4	3.8	1	6	4.5
CBUA 20	36	10	6	4.2	M5	7.5	11	5	M4	4	0	M5	8	12.25	22	17	12	8	4.5	4	5	1.5	8	4.5
CBUA 25	40	10	6	4.2	M5	7.5	14	6	M5	5	0	M5	8	12.75	26	22	15.6	8	4.5	4	5	1.5	8	5.5
CBUA 32	50	12	6	5.2	M6	9	17	8	M5	5	4	1/8"	8	14.5	32	28	19.8	10	5.5	4	6.5	2.5	10	6
CBUA 40	58	12	6	5.2	M6	9	17	10	M5	5	3	1/8"	8	14.75	42	33	23.3	10	5.5	4	6.5	2.5	10	6.5
CBUA 50	67	16	6	6.7	M8	10.5	22	10	M6	6	0	1/8"	8	14.75	50	42	29.7	13	6.5	4	7.5	2.5	12	7.5
CBUA 63	80	16	8	8.5	M10	13.5	22	10	M6	6	0	1/8"	8	14.25	62	50	35.4	13	8.5	4	7.5	2.5	12	7.5
CBUA 80	100	20	8	8.5	M10	13.5	28	14	M8	8	0	1/8"	8.5	16	82	65	46	17	8.5	4	9	3	14	8
CBUA 100	124	25	8	8.5	M10	13.5	30	14	M10	10	0	1/4"	10.5	19.25	103	80	56.6	22	8.5	4	10	3	14	10

Tipo / Type	Corsa / Stroke		H															
	5	10	15	20	25	30	40	50	60	70	80	90	100	125	160	200	250	
CBU 16	43	48	53	58	63	68	78	88	98	108	118	128	138	163	-	-	-	
CBU 20	43	48	53	58	63	68	78	88	98	108	118	128	138	163	-	-	-	
CBU 25	44.5	49.5	54.5	59.5	64.5	69.5	79.5	89.5	99.5	109.5	119.5	129.5	139.5	164.5	199.5	-	-	
CBU 32	49.5	54.5	59.5	64.5	69.5	74.5	84.5	94.5	104.5	114.5	124.5	134.5	144.5	169.5	204.5	244.5	-	
CBU 40	50.5	55.5	60.5	65.5	70.5	75.5	85.5	95.5	105.5	115.5	125.5	135.5	145.5	170.5	205.5	245.5	-	
CBU 50	50.5	55.5	60.5	65.5	70.5	75.5	85.5	95.5	105.5	115.5	125.5	135.5	145.5	170.5	205.5	245.5	295.5	
CBU 63	-	60	65	70	75	80	90	100	110	120	130	140	150	175	210	250	300	
CBU 80	-	66	71	76	81	86	96	106	116	126	136	146	156	181	216	256	306	
CBU 100	-	76.5	81.5	86.5	91.5	96.5	106.5	116.5	126.5	136.5	146.5	156.5	166.5	191.5	226.5	266.5	316.5	

# CILINDRI CORSA BREVE COMPATTI SHORT STROKE COMPACT CYLINDERS

## DIMENSIONI D'INGOMBRO / OVERALL SIZE

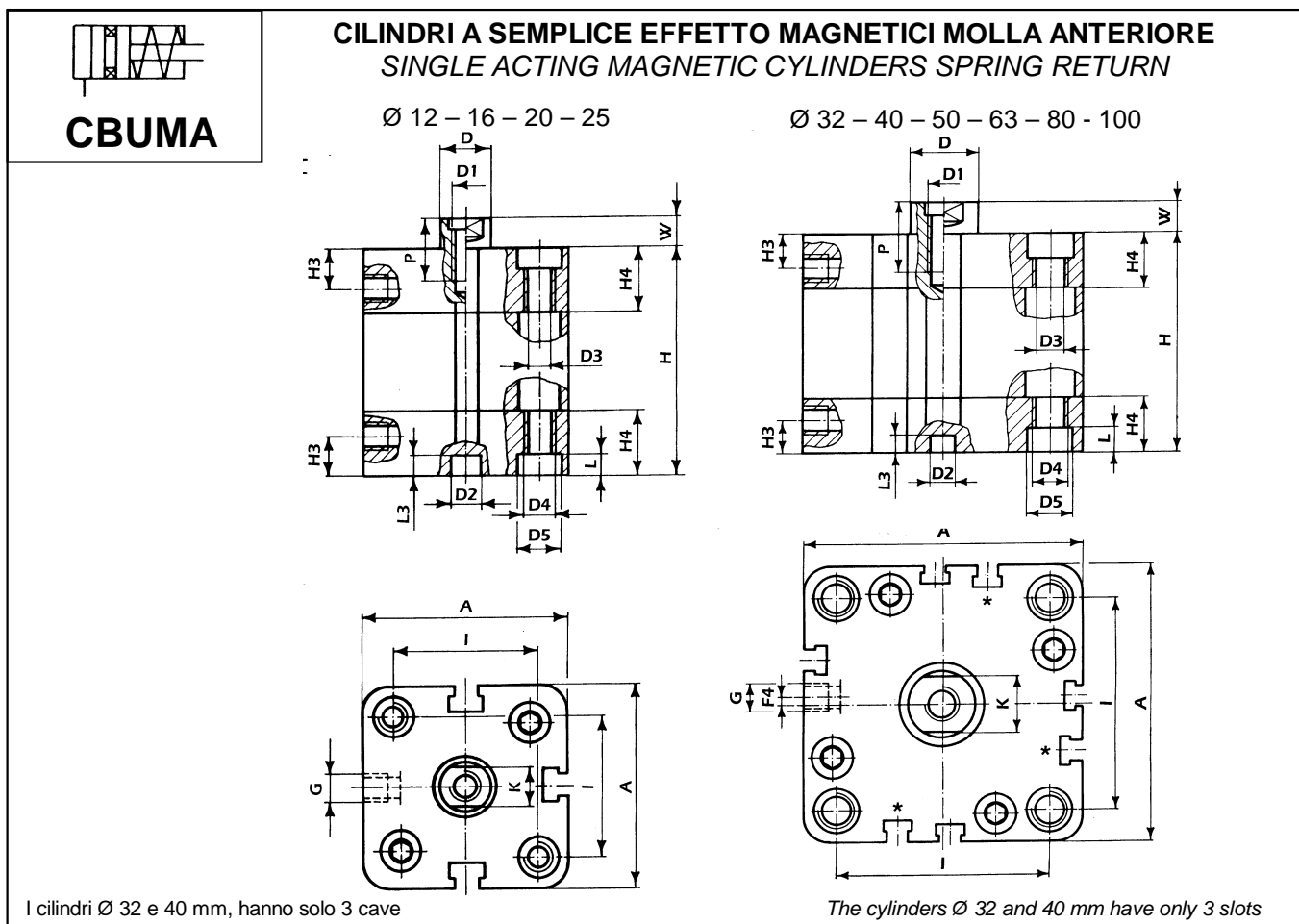

TIPO TYPE	A	D Ø	D1 Ø	D2 Ø	D3 Ø	D4 Ø	D5 Ø	F4	G	H3	H4	I	K	L	L3	P	W
CBUMA 12	29	6	M3	6	3.3	M4	6	0	M5	8	12.25	18	5	3.5	4	6	4.5
CBUMA 16	29	8	M4	6	3.3	M4	6	0	M5	8	12.25	18	6	3.5	4	8	4.5
CBUMA 20	36	10	M5	6	4.2	M5	7.5	0	M5	8	12.25	22	8	4.5	4	10	4.5
CBUMA 25	40	10	M5	6	4.2	M5	7.5	0	M5	8	12.75	26	8	4.5	4	10	5.5
CBUMA 32	50	12	M6	6	5.2	M6	9	4	1/8"	8	14.5	32	10	5.5	4	12	6
CBUMA 40	58	12	M6	6	5.2	M6	9	3	1/8"	8	14.75	42	10	5.5	4	12	6.5
CBUMA 50	67	16	M8	6	6.7	M8	10.5	0	1/8"	8	14.75	50	13	6.5	4	12	7.5
CBUMA 63	80	16	M8	8	8.5	M10	13.5	0	1/8"	8	14.25	62	13	8.5	4	14	7.5
CBUMA 80	100	20	M10	8	8.5	M10	13.5	0	1/8"	8.5	16	82	17	8.5	4	15	8
CBUMA 100	124	25	M12	8	8.5	M10	13.5	0	1/4"	10.5	19.25	103	22	8.5	4	20	10

Tipo / Type	Corsa / Stroke		H					
	5	10	15	20	25	30	40	50
CBUMA 12	43	48	53	58	63	78	88	98
CBUMA 16	43	48	53	58	63	78	88	98
CBUMA 20	43	48	53	58	63	78	88	98
CBUMA 25	44.5	49.5	54.5	59.5	64.5	89.5	99.5	109.5
CBUMA 32	49.5	54.5	59.5	64.5	69.5	94.5	104.5	114.5
CBUMA 40	50.5	55.5	60.5	65.5	70.5	95.5	105.5	115.5
CBUMA 50	50.5	55.5	60.5	65.5	70.5	95.5	105.5	115.5
CBUMA 63	-	60	65	70	75	100	110	120
CBUMA 80	-	66	71	76	81	116	126	136
CBUMA 100	-	76.5	81.5	86.5	91.5	126.5	136.5	146.5

# CILINDRI CORSA BREVE COMPATTI

## SHORT STROKE COMPACT CYLINDERS

### DIMENSIONI D'INGOMBRO / OVERALL SIZE

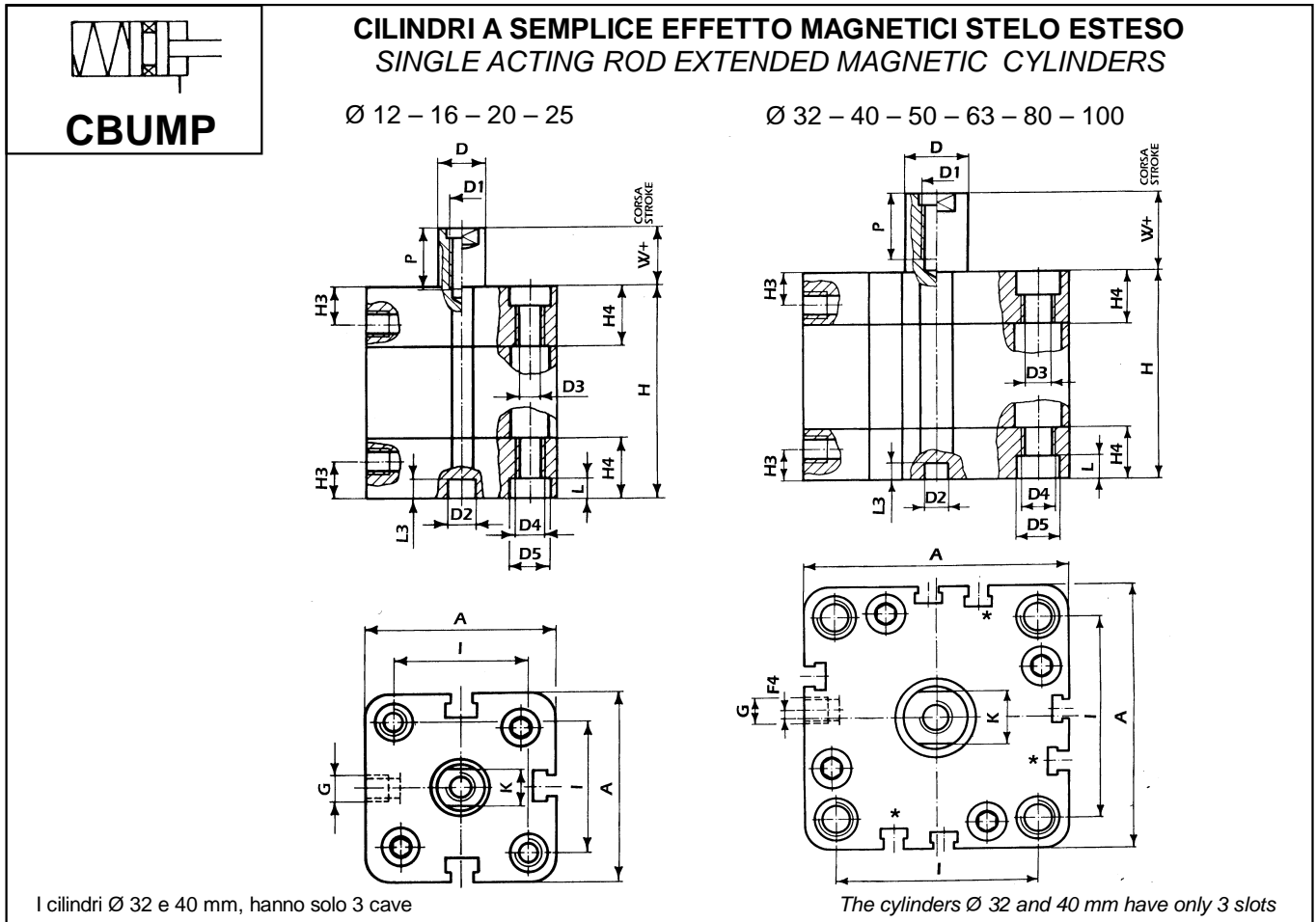

TIPO TYPE	A	D Ø	D1	D2 Ø	D3 Ø	D4 Ø	D5 Ø	F4	G	H3	H4	I	K	L	L3	P	W
CBUMP 12	29	6	M3	6	3.3	M4	6	0	M5	8	12.25	18	5	3.5	4	6	4.5
CBUMP 16	29	8	M4	6	3.3	M4	6	0	M5	8	12.25	18	6	3.5	4	8	4.5
CBUMP 20	36	10	M5	6	4.2	M5	7.5	0	M5	8	12.25	22	8	4.5	4	10	4.5
CBUMP 25	40	10	M5	6	4.2	M5	7.5	0	M5	8	12.75	26	8	4.5	4	10	5.5
CBUMP 32	50	12	M6	6	5.2	M6	9	4	1/8"	8	14.5	32	10	5.5	4	12	6
CBUMP 40	58	12	M6	6	5.2	M6	9	3	1/8"	8	14.75	42	10	5.5	4	12	6.5
CBUMP 50	67	16	M8	6	6.7	M8	10.5	0	1/8"	8	14.75	50	13	6.5	4	12	7.5
CBUMP 63	80	16	M8	8	8.5	M10	13.5	0	1/8"	8	14.25	62	13	8.5	4	14	7.5
CBUMP 80	100	20	M10	8	8.5	M10	13.5	0	1/8"	8.5	16	82	17	8.5	4	15	8
CBUMP 100	124	25	M12	8	8.5	M10	13.5	0	1/4"	10.5	19.25	103	22	8.5	4	20	10

Tipo / Type	Corsa / Stroke				
	5	10	15	20	25
CBUMP 12	43	48	53	58	63
CBUMP 16	43	48	53	58	63
CBUMP 20	43	48	53	58	63
CBUMP 25	44.5	49.5	54.5	59.5	64.5
CBUMP 32	49.5	54.5	59.5	64.5	69.5
CBUMP 40	50.5	55.5	60.5	65.5	70.5
CBUMP 50	50.5	55.5	60.5	65.5	70.5
CBUMP 63	-	60	65	70	75
CBUMP 80	-	66	71	76	81
CBUMP 100	-	76.5	81.5	86.5	91.5

# CILINDRI CORSA BREVE COMPATTI

## SHORT STROKE COMPACT CYLINDERS

### DIMENSIONI D'INGOMBRO / OVERALL SIZE

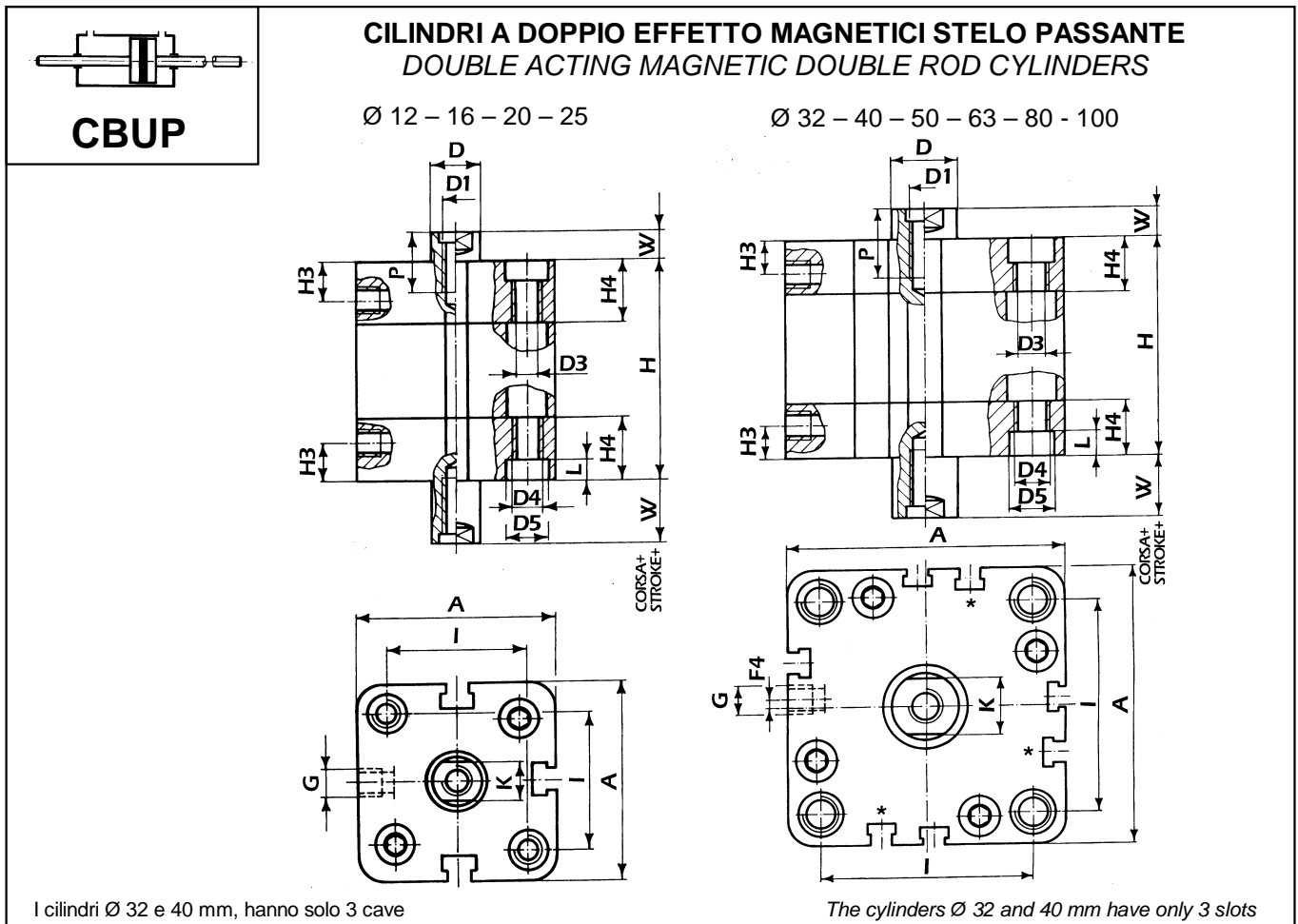

TIPO TYPE	A	D Ø	D1 Ø	D3 Ø	D4 Ø	D5 Ø	F4	G	H3	H4	I	K	L	P	W
CBUP 12	29	6	M3	3.3	M4	6	0	M5	8	12.25	18	5	3.5	6	4.5
CBUP 16	29	8	M4	3.3	M4	6	0	M5	8	12.25	18	6	3.5	8	4.5
CBUP 20	36	10	M5	4.2	M5	7.5	0	M5	8	12.25	22	8	4.5	10	4.5
CBUP 25	40	10	M5	4.2	M5	7.5	0	M5	8	12.75	26	8	4.5	10	5.5
CBUP 32	50	12	M6	5.2	M6	9	4	1/8"	8	14.5	32	10	5.5	12	6
CBUP 40	58	12	M6	5.2	M6	9	3	1/8"	8	14.75	42	10	5.5	12	6.5
CBUP 50	67	16	M8	6.7	M8	10.5	0	1/8"	8	14.75	50	13	6.5	12	7.5
CBUP 63	80	16	M8	8.5	M10	13.5	0	1/8"	8	14.25	62	13	8.5	14	7.5
CBUP 80	100	20	M10	8.5	M10	13.5	0	1/8"	8.5	16	82	17	8.5	15	8
CBUP 100	124	25	M12	8.5	M10	13.5	0	1/4"	10.5	19.25	103	22	8.5	20	10

Tipo / Type	Corsa / Stroke		H														
	5	10	15	20	25	30	40	50	60	70	80	90	100	125	160	200	250
CBUP 12	43	48	53	58	63	68	78	88	98	108	118	128	138	-	-	-	-
CBUP 16	43	48	53	58	63	68	78	88	98	108	118	128	138	163	-	-	-
CBUP 20	43	48	53	58	63	68	78	88	98	108	118	128	138	163	198	-	-
CBUP 25	44.5	49.5	54.5	59.5	64.5	69.5	79.5	89.5	99.5	109.5	119.5	129.5	139.5	164.5	199.5	-	-
CBUP 32	49.5	54.5	59.5	64.5	69.5	74.5	84.5	94.5	104.5	114.5	124.5	134.5	144.5	169.5	204.5	244.5	-
CBUP 40	50.5	55.5	60.5	65.5	70.5	75.5	85.5	95.5	105.5	115.5	125.5	135.5	145.5	170.5	205.5	245.5	-
CBUP 50	50.5	55.5	60.5	65.5	70.5	75.5	85.5	95.5	105.5	115.5	125.5	135.5	145.5	170.5	205.5	245.5	295.5
CBUP 63	-	60	65	70	75	80	90	100	110	120	130	140	150	175	210	250	300
CBUP 80	-	66	71	76	81	86	96	106	116	126	136	146	156	181	216	256	306
CBUP 100	-	76.5	81.5	86.5	91.5	96.5	106.5	116.5	126.5	136.5	146.5	156.5	166.5	191.5	226.5	266.5	316.5

# CILINDRI CORSA BREVE COMPATTI SHORT STROKE COMPACT CYLINDERS

## DIMENSIONI D'INGOMBRO / OVERALL SIZE

### CILINDRI CORSA BREVE CON INTERASSI ISO 6431 - VDMA SHORT STROKE CYLINDERS WITH INTERAXIAL MEASURES ISO 6431 - VDMA

**CBU... I  
CBUMA... I**

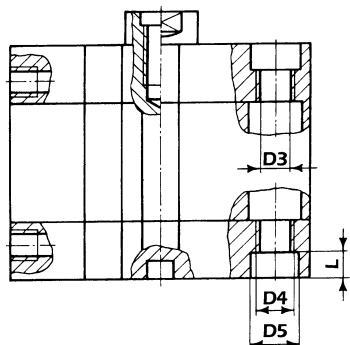

**CBUP... I**

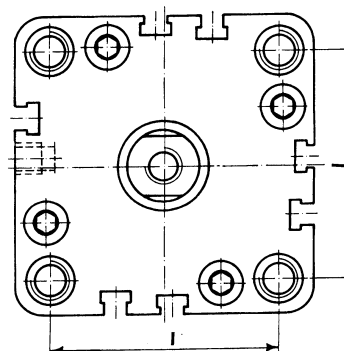
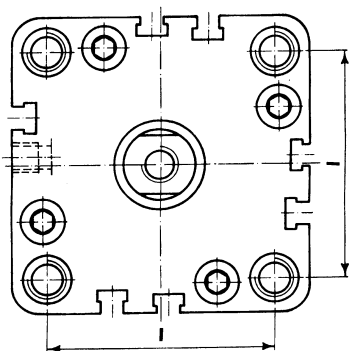
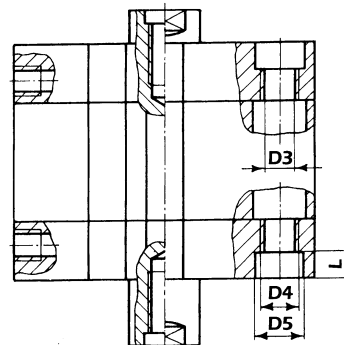

I cilindri CBU, CBUMA, CBUP, nei diametri da 32 a 100mm, possono essere forniti con gli interassi e le misure dei fori di fissaggio, secondo le norme ISO 6431 – VDMA.

Questa pagina mostra solo le misure degli interassi e dei fori di fissaggio, mentre le altre dimensioni rimangono invariate.

*The CBU, CBUMA, CBUP, in diameters from 32 to 100 mm, can be supplied with interaxial and fixing bores measures according to ISO 6431 – VDMA rules.*

*This page shows only interaxial and fixing bores measures, while the other dimensions remain unchanged.*

Tipo Type	Ales. Bore	D3 Ø	D4 Ø	D5 Ø	I	L
CBU ... I	32	5.2	M6	9	32.5	5.5
	40	5.2	M6	9	38	5.5
CBUMA ... I	50	6.7	M8	10.5	46.5	6.5
	63	6.7	M8	10.5	56.5	6.5
CBUP... I	80	8.5	M10	13.5	72	8.5
	100	8.5	M10	13.5	89	8.5

**NORME PER L'ORDINAZIONE / How to fill in your order:**

**CBU 40 50**

Tipo Alesaggio Corsa  
Type Bore Stroke

**CBU** = doppio effetto magnetici / *double acting magnetic*

**CBUA** = doppio effetto magnetici antirotativi / *double acting magnetic antirotary*

**CBUP** = doppio effetto magnetici stelo passante / *double acting magnetic double rod*

**CBUMA** = semplice effetto magnetici molla anteriore / *single acting magnetic spring return*

**CBUMP** = semplice effetto magnetici molla posteriore / *single acting magnetic spring extend*

**... I** = cilindri con interassi ISO 6431 – VDMA / *cylinders with interaxial measures ISO 6431 - VDMA*



# CILINDRI CORSA BREVE COMPATTI SHORT STROKE COMPACT CYLINDERS

## INTERRUTTORI MAGNETICI DI PROSSIMITA' / PROXIMITY MAGNETIC SWITCHES

Adatti per essere montati su: cilindri ISO 6431 serie / ISO 6431 cylinders series **EU2**  
 For to be assembled: cilindri compatti serie / compact cylinders series **CBU**  
 microcilindri ISO serie / ISO microcylinders series **ME\***  
 \* con staffe di ancoraggio / \*with sensor support

1

### tipo SM5L / type SM5L

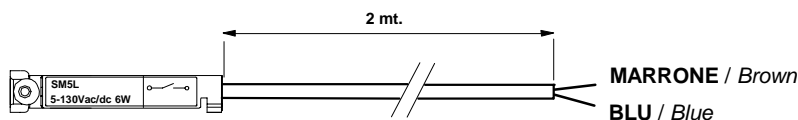

### tipo SM5L-300-M8 / type SM5L-300-M8

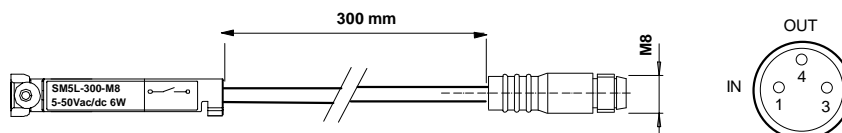

contatto / contact

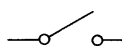

Indicazione di commutazione  
switching indication

LED

Tensione nominale / rated voltage

- corrente continua / direct current	V dc	5...130
- corrente alternata / alternating current	V ac	5...130
- versione con connettore M8	V ac	5...50
- version with M8 connector		
- caduta di tensione max. / max voltage drop	V	3

Corrente di azionamento / operating current mA 200

Carico max. applicabile / max applicable load W 6  
VA 6

Vita elettrica (carico resistivo) / Electric life (resistive load) 10<sup>7</sup>

Tempo di azionamento / operating time ms 0,5

Tempo di rilascio / release time ms 0,2

Temperatura ambiente / room temperature  
Cavo fisso / fixed cable °C -20... +60  
Cavo mobile / mobile cable °C -5... +60

Lunghezza cavo / lenght cable Mt 2

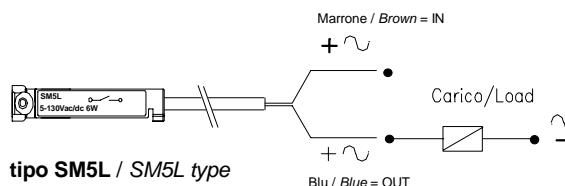

tipo SM5L / SM5L type

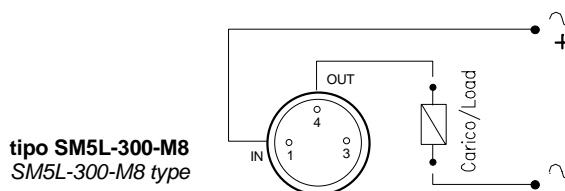

tipo SM5L-300-M8  
SM5L-300-M8 type

Gli interruttori magnetici SM5L sono sensori di prossimità elettrici. L'avvicinarsi di un campo magnetico determina l'azionamento del contatto Reed presente nel circuito del sensore. Il sensore va sempre collegato in serie al carico. Grazie alle scanalature presenti sui cilindri della serie CBU, il sensore viene montato in maniera semplice e veloce, senza l'ausilio di fascette, senza sporgere dalla sagoma del cilindro. Il sensore è anche disponibile nella versione a 3 fili e nella versione con la parte terminale del cavo con connettore normalizzato M8.

Magnetic switches SM5L are proximity electric sensor. The approach of a magnetic field determines the control of the reed contact that is in the sensor's circuit. The sensor is always connect in series to the load. Thanks to the CBU cylinders's splines the sensor is assembled in a simple and fast way, without any clamps, which do not extend themselves from the structure of the cylinder. The sensor can be available in a version with three thread and in that with the end of the hollow with normalized M8 connector.

**NB.** Per le caratteristiche tecniche consultare il paragrafo "Sensori magnetici" pag. 1.13.00  
 For Technical features refer to "Magnetic sensor" 1.13.00 page